

Gardner Denver

STAINLESS STEEL FOOD & CHEMICAL PUMP

STP 125



The STP125 is a 3A Certified Sanitary, stainless steel pump specifically designed for the transfer of food-grade products or chemicals from tank trailers. Its lightweight and compact design makes it ideal for tank truck applications.

Maintenance & Flexibility

- Front loading product seal can be changed in minutes without disturbing the product pump head or piping
- Seal design allows you to choose the correct seal type for your application (O-ring, double lip, or mechanical seal)
- Quick Strip design makes cleaning and maintenance fast and efficient
- Low shaft deflection enables quiet and smooth operation
- Hydraulic direct mount and top shaft drive available

Low Operation Costs

- Bi-directional pressure relief valve provides protection while loading or unloading
- Rotor profile and pump chamber designed using Computational Fluid Dynamics to ensure quiet, pulse-free, cavitation-resistant flow



Optional Heat Saddles



Rotor removal tool is provided with every pump.



Specifications

- Flow rate: up to 232 gpm
- Maximum speed: 750 rpm
- Maximum pressure: 140 psi
- Weight: 145 lbs. (with relief valve)
- Suitable for temperatures up to 300°F

Drives

- Hydraulic direct mount
- Top shaft

Seal Options

- Standard: Nitrile O-ring seal assembly
- Optional O-ring Material: EPDM or Viton® and Double Lip seal configurations available
- Mechanical seals
- Available Ports
- Standard: 3" male ACME
- Optional: 3" male camlock or 3" male NPT (special order)

Applications

- Sugars
- Fruit Juice
- Chocolate
- Vegetable Oils
- Dairy Products
- Starches

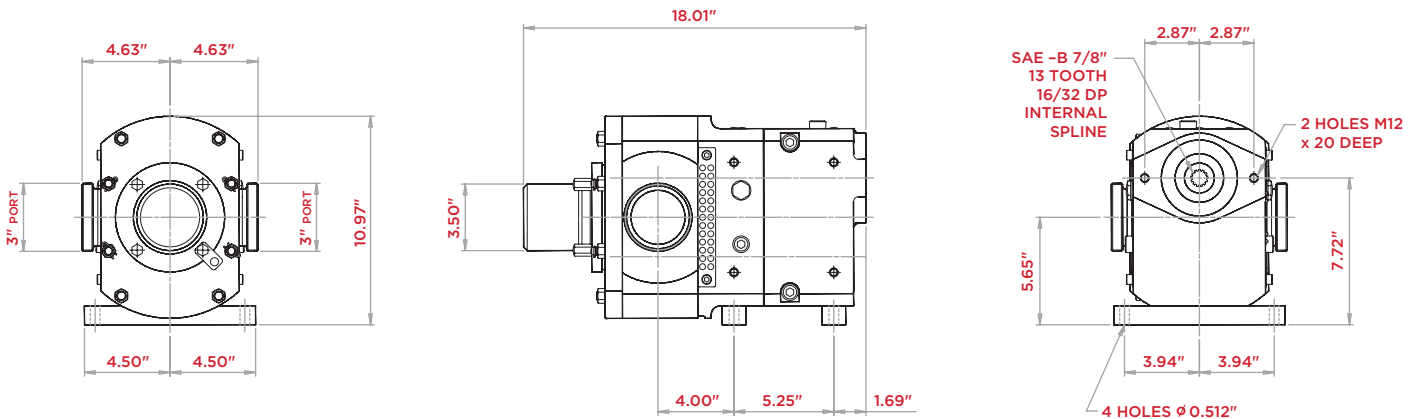

The leader in every market we serve
by continuously improving all business processes
with a focus on innovation and velocity

**Gardner
Denver**[®]

Gardner Denver, Inc.

1800 Gardner Expressway
Quincy, IL 62305
866-376-8181

www.gardnerdenver.com/gdproducts



©2019 Gardner Denver, Inc. Printed in U.S.A.
GDT-STP-125 2nd Ed. 7/19

Please recycle after use.